

TEC-25V-20A-PID

Operating Manual

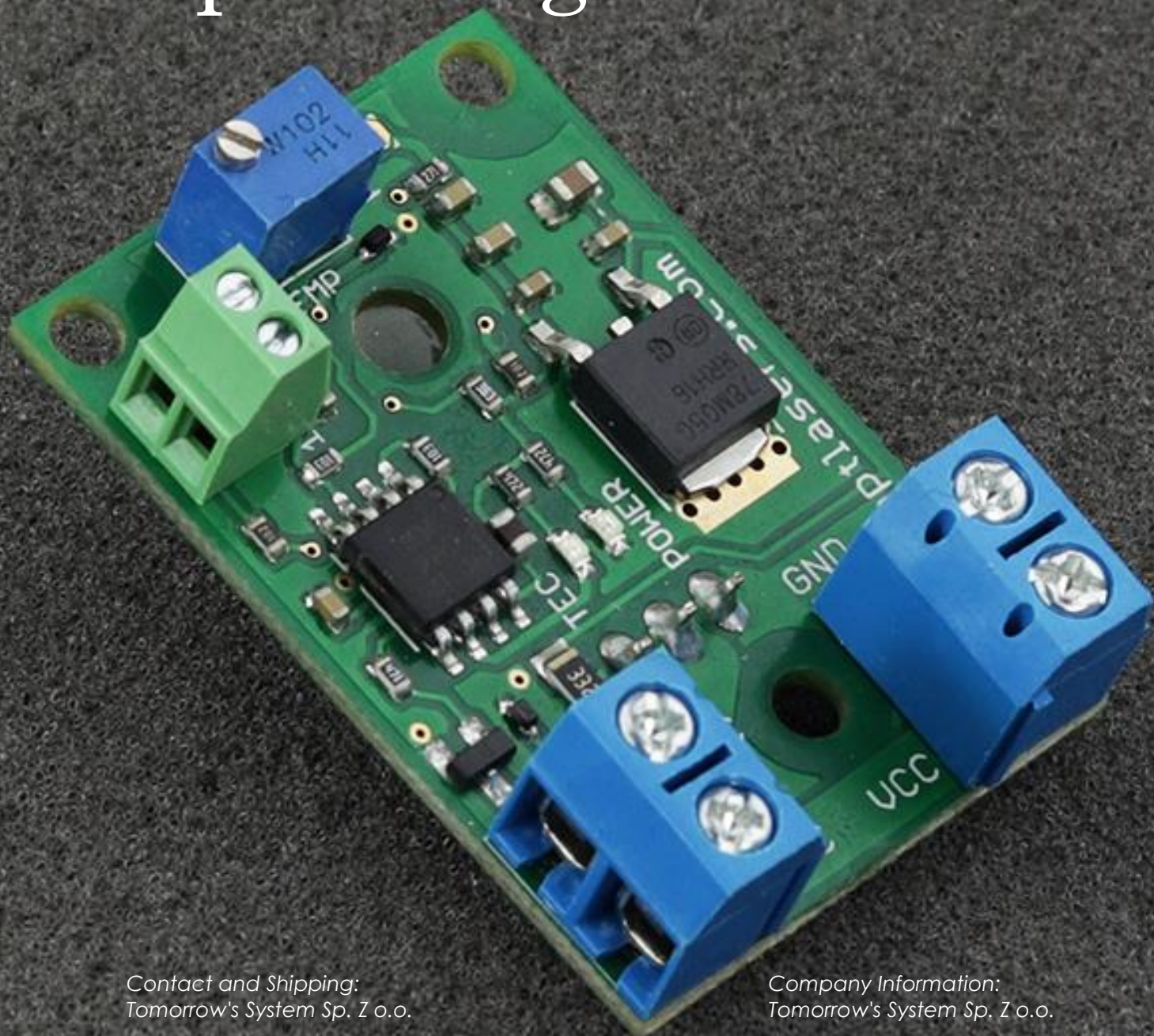

Contact and Shipping:
Tomorrow's System Sp. Z o.o.

Okulickiego 7/9 hala G39
05-500 Piaseczno
Poland
tel.: +48 515 180 752

Company Information:
Tomorrow's System Sp. Z o.o.

Pułaskiego 125/35
15-337 Białystok
Poland
NIP: PL5423238556

Table of Content

Product Description..... 3

Technical Data..... 4

How to connect the TEC controller..... 4

Recommendations and requirements 5

Setting the temperature 6

Dimensions..... 7

Product Description



This is an advanced TEC controller using a microprocessor unit.

Thanks to PID algorithm additional heat is not dissipated on the mosfet since driver uses PWM modulation for current controlling.

Due to the fact that the driver is working in a cooling mode, it was possible to use fewer elements, make the board smaller and improve the overall efficiency.

Thanks to a two-layer board and wide paths it is possible to use TECs with up to 20A. Connectors allow to use maximum current of 13A so if there is a need to use bigger Peltier cells, wires should be soldered directly into the driver's PCB board.

Maximum current flowing through the device depends on a TEC used. Voltage dropout on a driver is very small so current can be predicted by reading TEC labels.

For example, 12704 means 12V and 4A, whereas 12715 means 12V and 15A.

It is possible to change stabilization temperature range, please write us an email if needed.



Technical Data

Supply voltage (V)	7 - 25
Temperature sensor	10k NTC B3950
Temperature stabilization accuracy	$\pm 0,2^{\circ}\text{C}$
TEC indicator	YES - blue LED diode
Maximum current (A)	20
Power indicator	YES - green LED diode
Temperature range	10 - 40°C
Dimensions (LxW mm)	26,7 x 39,4

How to connect the TEC controller

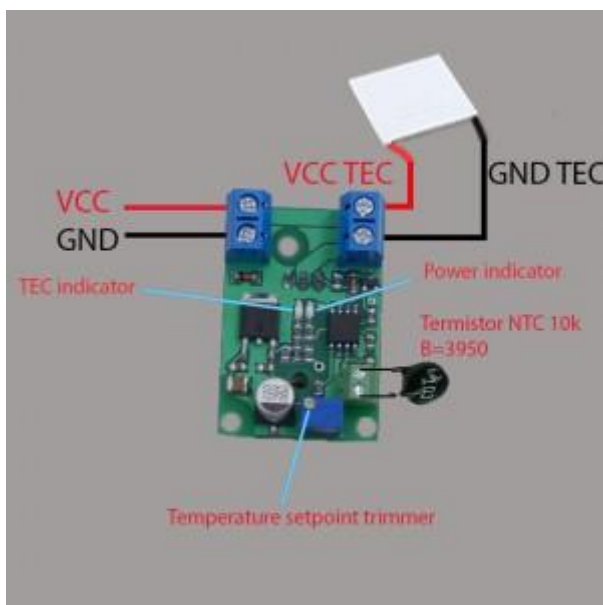

TECs can be connected parallel or in series. Please remember that high current needs proper wiring with bigger cross section of the cables.

Correct connection of power supply and other components is very important. supply voltage must be kept within the limits of 7-25V. Incorrect connection can damage the driver.

The driver has a temperature sensor connector. It is recommended to use a 10k NTC sensor.



Recommendations and requirements

We recommend the use of power cables with a minimum cross-section of 1 mm².

The MOSFET must be isolated from the heatsink/plate with a silicon pad as well as plastic sleeve (included). Short circuit between MOSFET and heatsink/plate can damage the driver and can be dangerous for the device. Mosfet temperature should be monitored and cannot exceed 70 degrees Celsius.



Setting the temperature

Before setting the temperature, the temperature sensor with a display (or pyrometer) and a screwdriver should be prepared.

1. Turn on the power.
2. If the blue LED state is high, rotate the potentiometer counterclockwise until the LED goes off



3. Next, slowly rotate the potentiometer clockwise until the blue LED lights up, which means that TEC is running and temperature is decreasing. After reaching the desired temperature turn the potentiometer a little counterclockwise in order to make the blue

LED off. By doing so, you can achieve a state of temperature balance. Exact temperature can be read thanks to a temperature sensor with a display or a pyrometer.

4. If the temperature is too high then rotate the potentiometer clockwise and wait until the LED starts blinking.

Check the temperature.



Dimensions

